

Calipers

An industry standard in measuring tools

Dial Caliper Series 505

- Newly designed dial movement for ultra-smooth sliding and high shock protection.
- Titanium coating is applied to the sliding surfaces to enhance the durability (except for 0 - 300mm and 0 - 12" model).
- Easy-to-read yellow dial.
- Large finger-rest aids ease-of-use.
- Jaw tips are relieved for easy measurement of thin parts.
- Allows step measurement.

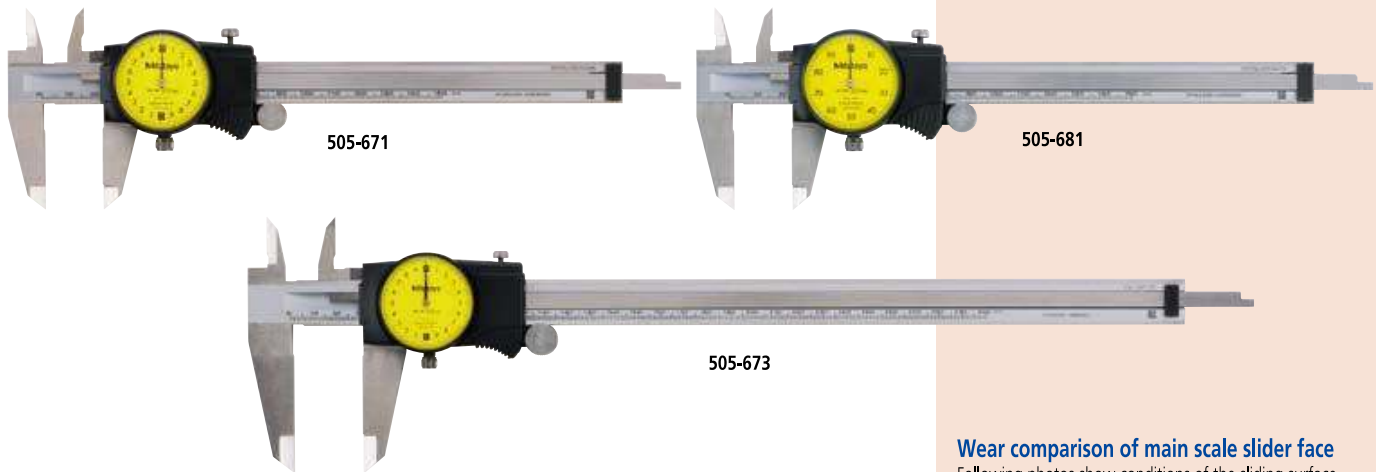

An inspection certificate is supplied as standard. Refer to page IX for details.

SPECIFICATIONS

D

Metric					
Order No.	Range	Accuracy	Graduation	Remarks	
505-680	0 - 100mm	±0.015mm	0.01mm, 1mm/rev	—	
505-671 / 505-683*	0 - 150mm	±0.03mm	0.02mm, 2mm/rev	Carbide-tipped jaws for outside measurement	
505-707				Carbide-tipped jaws for outside and inside measurement	
505-711					
505-681 / 505-685*					
505-672 / 505-684*	0 - 200mm	±0.03mm	0.02mm, 2mm/rev	—	
505-682 / 505-686*					
505-673	0 - 300mm	±0.04mm	0.02mm, 2mm/rev		

* Silver cover type

Inch						
Order No.	Range	Accuracy	Graduation	Remarks		
505-674	0 - 4"	±.001"	.001", .1"/rev	—		
505-675 / 505-689*	0 - 6"	±.001"		Carbide-tipped jaws for outside measurement		
505-708		±.001"		Carbide-tipped jaws for outside and inside measurement		
505-712		±.001"				
505-676 / 505-690*		±.002"				
505-709	0 - 8"	±.002"		Carbide-tipped jaws for outside measurement		
505-713		±.002"		Carbide-tipped jaws for outside and inside measurement		
505-720		±.002"		.001", .2"/rev	—	
505-677*	0 - 12"	±.002"		.001", .1"/rev	—	
505-721		±.002"		.001", .2"/rev	Carbide-tipped jaws for outside measurement	
505-710*		±.002"	.001", .1"/rev	Carbide-tipped jaws for outside and inside measurement		
505-714*		±.002"	.001", .1"/rev			

* Silver cover type

Wear comparison of main scale slider face

Following photos show conditions of the sliding surface after a sliding test comprising 100,000 movements. Smooth movement over the entire measuring range is assured even when you use a particular part of the sliding surface repeatedly.

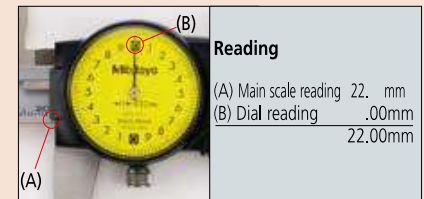
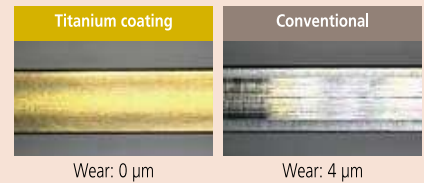

Reading

(A) Main scale reading 22. mm
(B) Dial reading .00mm
22.00mm



DIMENSIONS

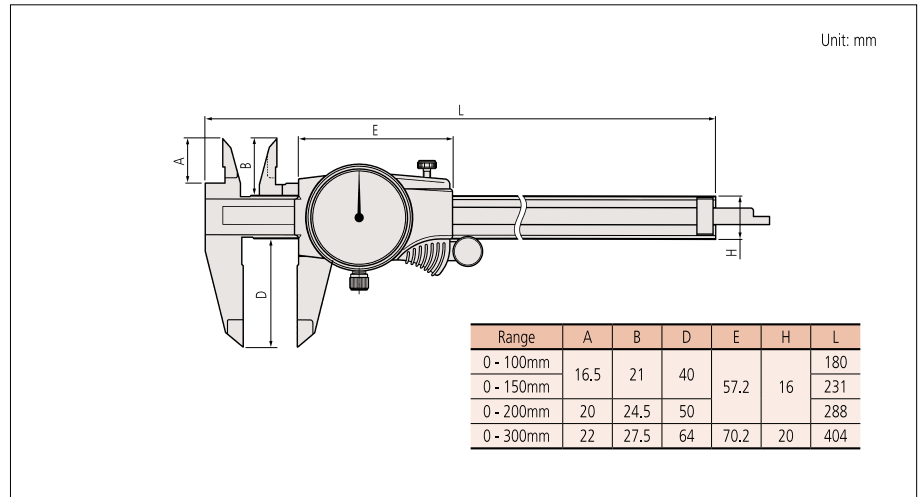

D